

MODEL 521 Light Duty Parts or Bulk Material Handling Conveyor

This unit is designed to convey unboxed, loose products like plastic parts and stampings and for conveying bulk products like sludge or sand. It features a low profile infeed and small hold down wheels for easy placement under existing machines.

These units lower profile frame, shorter cleats, lower side rails and the use of 1-7/8" diameter hold wheels allow it to fit into tight spaces other units can not.

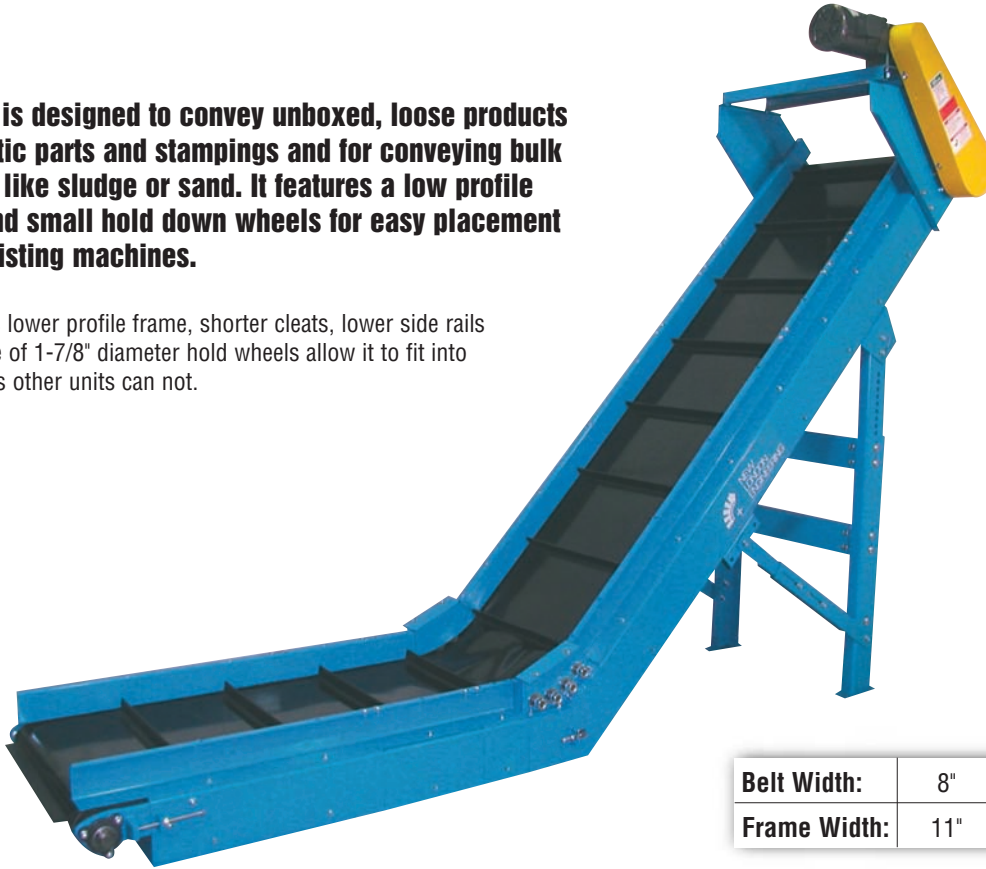

Corrugated belt options are also available as shown on the next page

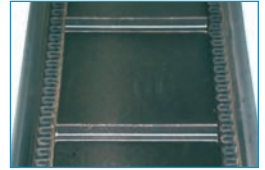

Hold Down Wheels Front View

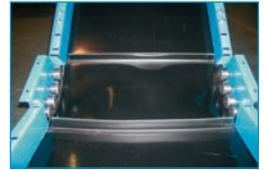

Hold Down Wheels Inside of Frame View



Belt Width:	8"	12"	18"	24"
Frame Width:	11"	15"	21-1/2"	28"

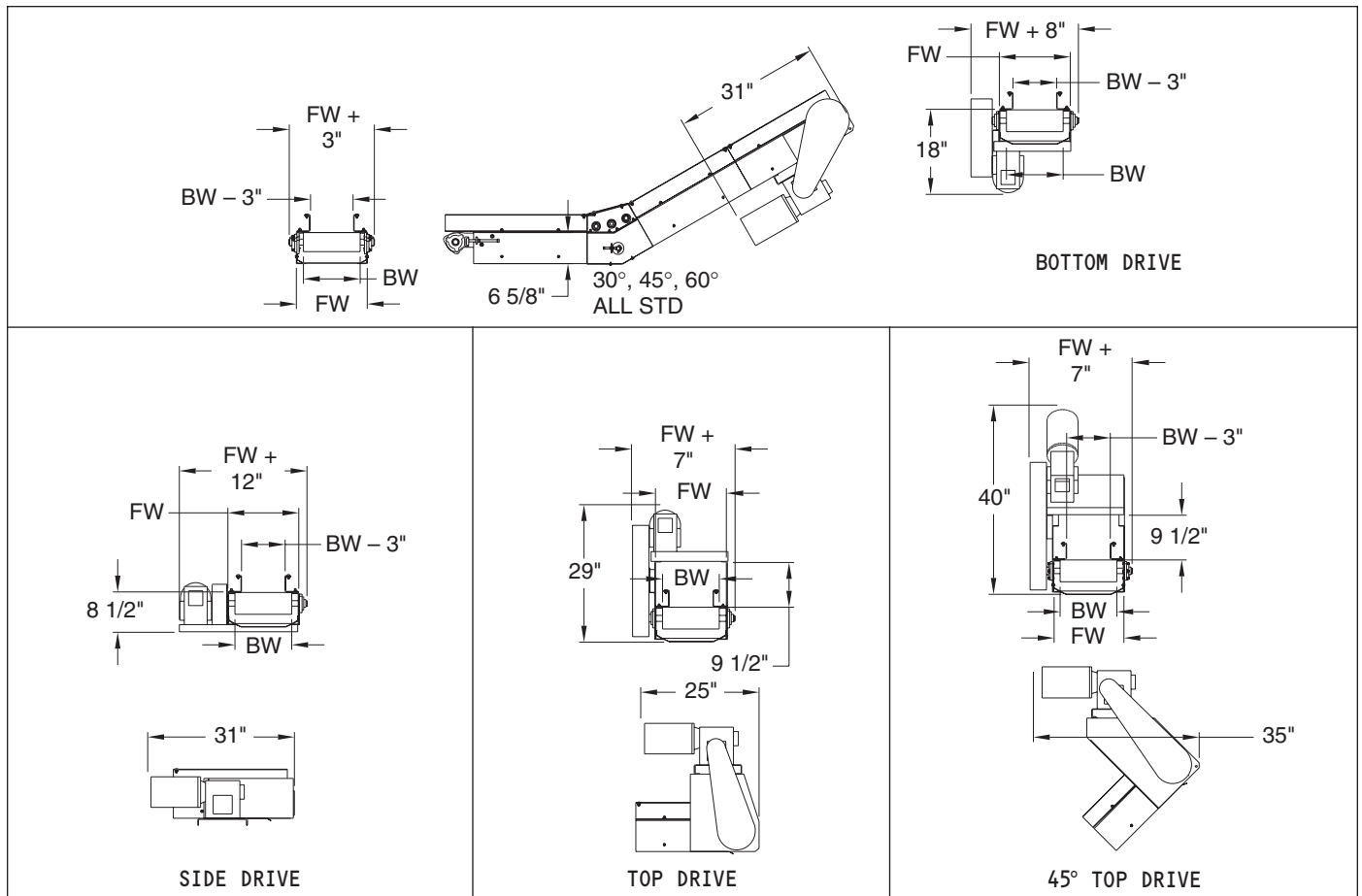

MODEL 521 Light Duty Parts or Bulk Material Handling Conveyor

Standard Specifications

Widths: Up to 24"

Curves: 30, 45 & 60 Degree

Hold Down Wheels: 1-7/8" dia. x 3/4" Face Cams
 30° = 3 Cams Per Side;
 45° & 60° = 4 Cams Per Side

Standard Speed: 30 FPM

Standard Motor: 1/3 HP 230/460/3/60 TEFC

Standard Drive: Top Mount, Right Side

Drive Pulley: 4" Dia Crown Face Rubber Lagged x 1-3/16"

Infeed Pulley: 4" Dia Crown Face Take Up x 1-3/16"

Frame: 6-5/8" Deep x 12 Gauge

Standard Side Rails: 1-1/2" or 3-1/2" High

Standard Belt: Black PVC 120 with 1-1/2" High Cleats on 12" Centers, #1 Unibar Lacing

Corrugated Belt: Black PVC 120 with 1" High Cleats on 12" Centers x 1-1/2" High Corrugation x #1 Unibar Lacing

Inclined Conveyors Comparison Chart

Inclined Conveyors – "S" Shaped Units – Horizontal to Incline (Type II) – Horizontal to Incline to Horizontal (Type III) – Incline to Horizontal (Type IV) —

These units use cleated belts to carry loose, unpacked items like plastic parts, nuts & bolts and stampings from a horizontal position up an incline.

MODEL	DESCRIPTION	FRAME GAUGE	FRAME DEPTH	DRIVE PULLEY SIZE	DRIVE PULLEY TYPE*	DRIVE PULLEY SHAFT DIA.	INFEED PULLEY SIZE	INFEED PULLEY TYPE*	INFEED PULLEY SHAFT DIA.	STANDARD BELT	STD. DRIVE	OTHER
521	Light duty parts or bulk material handling conveyor	12	6.625"	4.5"	CFRL pulley	1.1875"	4"	CF pulley	1.1875"	3 ply RMV with 1-1/2" cleats on 12" centers 1-1/2" wall x 1" cleats for bulk applications	Top	- 1-1/2" or 3/12" side rails - 1-7/8" dia. x 3/4" face hold down wheels - 30°, 45° and 60° inclines std
361	Standard duty V-guided type II, III & IV conveyor**	12	6.625"	4.625"	FFRL "A" section	1.1875"	4.25"	FF "A" section	1.1875"	2 ply black PVC 120 with 1-1/2" cleats on 12" centers "A" section	Top	V-guided M521
590	Medium to heavy duty parts or bulk material conveyor	10	13"	8.625"	CFRL pulley	1.4375"	8"	CF pulley	1.4375"	- 2 ply 150 cross rigid x 3" cleats on 12" centers	Top	(2) 12" diameter x 2" wide deflection hold down wheels - 3" high wall x 2-1/2" cleats for bulk app.
591	Heavy duty parts or bulk material conveyor	10	13"	8.625"	CFRL pulley	1.6875"	8"	CF pulley	1.4375"	- 2 ply 150 cross rigid x 3" cleats on 12" centers	Top	- Heavy drive shaft M590 - (2) 12" diameter x 2" wide deflection hold down wheels - 3" high wall x 2-1/2" cleats for bulk app.

*BM = Bottom Mount; CF = Crown Faced; CDBM = Center Drive Bottom Mount; CH = Channel; FF = Flat Faced; RL = Rubber Lagged; RA = Right Angle; Std = Standard

**Type II = Horizontal to Incline; Type III = Horizontal to Incline to Horizontal; Type IV = Incline to Horizontal

Model 521, 361, 590 & 591 Worksheet

Model	General Guidelines	Hold Down Wheels	Minimum cleated belt recess per side = Belt Width x .10 Minimum corrugate belt recess per side = (Belt Width + Sidewall Height) x .10 Effective Width = Belt Width - (Recess + Corrugated wall width)
521 & 361	Maximum recommended length is 20'	45 & 60 degree (4) cams per side rather than (3)	Minimum belt recess = 3" per side
590 & 591	Consult NLE	(2) 12" hold down wheels	Corrugated wall width = 2" per side

	MODEL 521 & 361 CLEATED ONLY				MODEL 521 & 361 CLEATED & SIDEWALLS			MODEL 590 & 591 CLEATED ONLY					MODEL 590 & 591 CLEATED & SIDEWALLS				
Belt Width	8"	12"	18"	24**	12"	18"	24**	12"	18"	24"	30"	36"	14"	18"	24"	30"	36"
Effective Width	5"	9"	15"	21"	6"	12"	18"	6"	12"	18"	24"	30"	6"	8"	14"	20"	26"

*These are the maximum widths available. The M590 effective widths are for the standard belt with 3" high x 2-1/2" mini sidewall corrugation.

Unit Weights (Shipping Weights – lbs.)

BELT WIDTHS	8"	12"	18"	24"
LENGTHS				
4'	267	300	333	364
8'	322	374	426	477
12'	413	485	557	629
16'	468	559	650	742
20'	559	670	7781	894
24'	614	744	874	1007
28'	705	855	1005	1159
Add For Each Curve	43	50	62	74

Conveyor weights include standard drive, supports and 1-1/2" high rails. Other options, crating etc. are not included.

Skid Dimensions

Model 521 —

Note: these are general guidelines for freight rate estimates only. Final dimensions may vary.

BELT WIDTHS	8"	12"	18"	24"
Bottom and Top Mount Skid Width	20"	24"	30"	36"
Shaft and Side Mount Skid Width	32"	36"	42"	48"

Skid Length – These units are typically shipped assembled.

The skid length is the overall length + 5". Maximum skid length is 27'.