

MODEL 506 Heavy Duty Inclining Conveyor

(The Model 506 is a heavy drive shaft Model 505)

This unit features a 13" deep frame, 3" high cleats, 6" high side rails and large drive pulley. It is designed to move larger and heavier products up inclines. This sturdy, solid conveyor is built to last and withstand heavy usage.

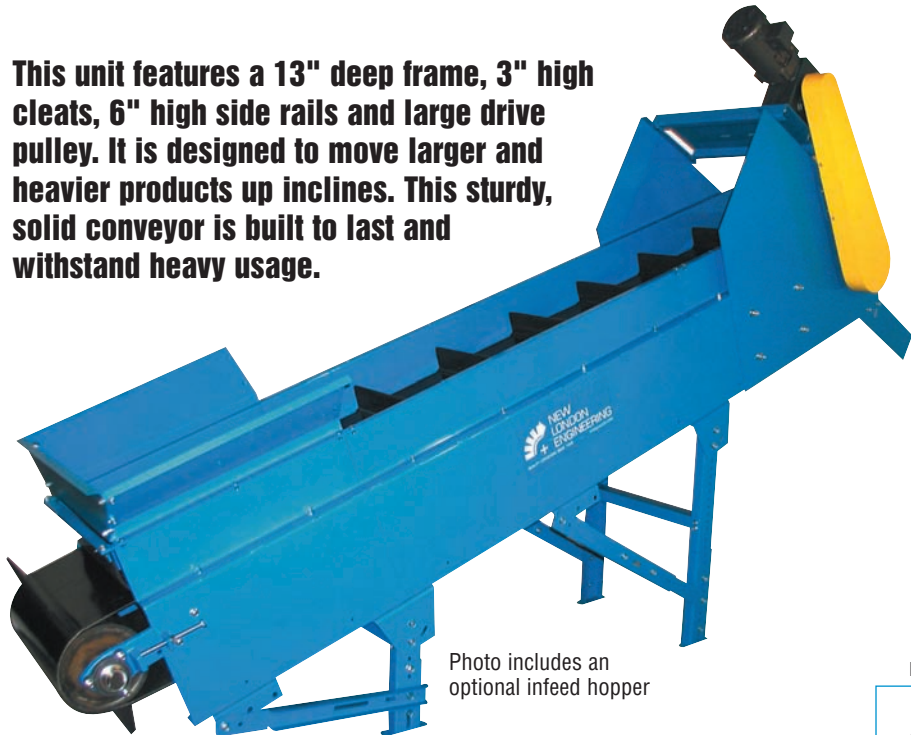

Photo includes an optional infeed hopper

Unit shown with bottom mount drive



Flared infeed hoppers



Belt shown with cleats.

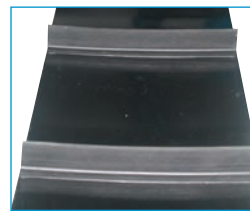

Belt Width:	12"	18"	24"	30"	36"	48"
Frame Width:	15"	21-1/2"	28"	34"	40"	52"

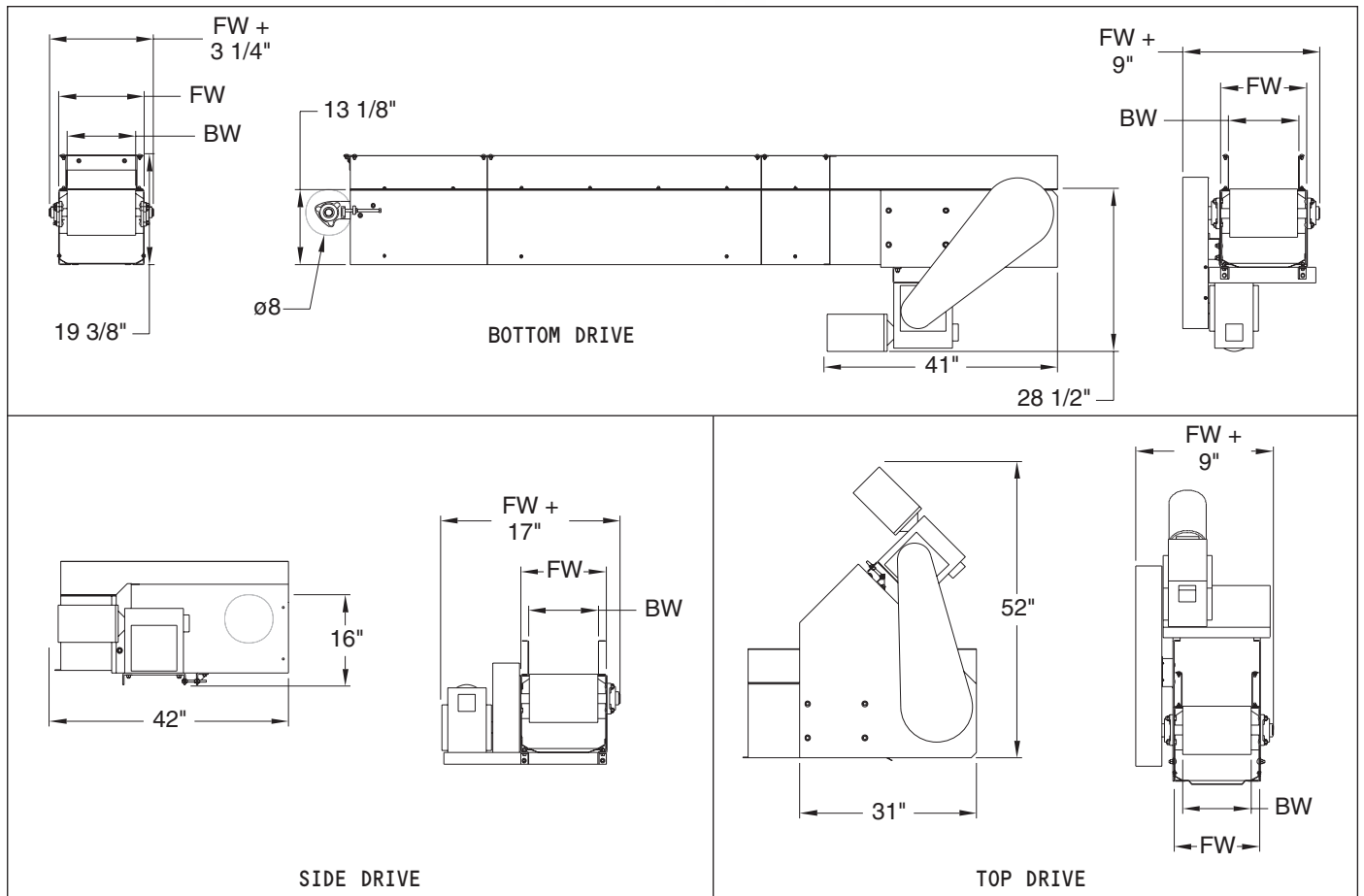

MODEL 506 Heavy Duty Inclining Conveyor

Standard Specifications

Widths: 12" – 48"

Lengths: 5' – 25' (6" Increments)
Standard Length is 5', Two Piece Bolt Together

Standard Speed: 60 FPM

Standard Motor: 3/4 HP 230/460/3/60 TEFC

Standard Drive: Top Mount, Right Side

Standard Belt: Black PVC 120 with 3" high cleats on 12" centers, Clipper Lacing

Drive Pulley: 8" Dia Crown Face Rubber Lagged x 1-11/16"

Infeed Pulley: 8" Dia Crown Face Take Up x 1-7/16"

Frame: 13" Deep x 10 Gauge

Bearings: Grease Sealed

Others: Base unit includes 6" high side rails and bottom pan

Inclined Conveyors – Horizontal Inclined Units Comparison Chart

Inclined Conveyors – Horizontal Inclined Units — These units use cleated belts to carry loose, unpacked items like plastic parts, nuts & bolts and stampings up inclines

MODEL	DESCRIPTION	FRAME GAUGE	FRAME DEPTH	DRIVE PULLEY SIZE	DRIVE PULLEY TYPE*	DRIVE PULLEY SHAFT DIA.	INFEED PULLEY SIZE	INFEED PULLEY TYPE*	INFEED PULLEY SHAFT DIA.	STANDARD BELT	STD. DRIVE*	OTHER
150	Standard duty low profile inclining conveyor	12	1.75" + cleat height	2.875"	CF knurled pulley	.75"	1.3125"	FF pulley	.5"	2 ply black PVC 70	Bottom	Note: Frame depth changes with cleat height
500	Standard duty inclining conveyor	12	6.625"	4.625"	CFRL pulley	1.1875"	4"	CF pulley	1.1875"	2 ply black PVC 120 with 1-1/2" cleats on 12" centers	Top	Unit includes 1-1/2" or 3/12" rails and a bottom pan
505	Medium duty inclining conveyor	10	13"	8.625"	CFRL pulley	1.4375"	8"	CF pulley	1.4375"	2 ply black PVC 120 with 3" cleats on 12" centers	Top	Unit includes 6" high siderails
506	Heavy duty inclining conveyor	10	13"	8.625"	CFRL pulley	1.6875"	8"	CF pulley	1.4375"	2 ply black PVC 120 with 3" cleats on 12" centers	Top	Heavy drive shaft M505
351	Standard duty V-guided inclining conveyor	12	6.625"	4.625"	FFRL "A" section	1.1875"	4"	FF "A" section	1.1875"	2 ply black PVC 120 with 1-1/2" cleats on 12" centers "A" section	Top	V-guided M500

*BM = Bottom Mount; CF = Crown Faced; CDBM = Center Drive Bottom Mount; CH = Channel; FF = Flat Faced; RL = Rubber Lagged; RA = Right Angle; Std = Standard

Unit Weights (Shipping Weights – lbs.)

BELT WIDTHS	12"	18"	24"	30"	36"	40"	48"
LENGTHS							
5'	508	564	620	672	724	776	829
10'	665	763	847	924	1002	1090	1179
15'	858	999	1112	1215	1320	1445	1571
20'	1015	1198	1339	1467	1598	1759	1921
25'	1208	1434	1604	1758	1916	2114	2313
30'	1365	1633	1831	2010	2194	2428	2663

Conveyor weights include standard drive, supports and 6" high siderails. Other options, crating etc. are not included.

Skid Dimensions

Model 506 — Note: these are general guidelines for freight rate estimates only. Final dimensions may vary.

BELT WIDTHS	12"	18"	24"	30"	36"	48"
Bottom, Top & Center Mount Skid Width	25"	30"	41"	41"	47"	59"
Shaft and Side Mount Skid Width	30"	41"	41"	46"	52"	64"

Skid Length – These units are typically shipped assembled. The skid length is the overall length + 12". Maximum skid length is 27'.