

# 199-CREZD

## Heavy Duty Accumulating Conveyor (Zero Pressure Accumulating Type)

The Model 199-CREZD is a chain driven live roller conveyor designed for zero pressure accumulation of products. This conveyor is designed to handle cartons or pallets in conditions that may not be suitable for belt driven rollers. Products may be accumulated in zones and released upon request.

- EZDrive™ System (Individual zone drive)
- EZLogic® Accumulation System
- Chain Driven Rollers
- Shaft Mounted Drive
- Adjustable MSN-Type Floor Supports Available



HYTROL CONVEYOR COMPANY, INC.

Conveying Surface	12 1/4"	14 1/4"	16 1/4"	18 1/4"	20 1/4"	22 1/4"	24 1/4"	28 1/4"	30 1/4"	34 1/4"	36 1/4"
Between Rail Width	15"	17"	19"	21"	23"	25"	27"	31"	33"	37"	39"
Overall Frame Width	18"	20"	22"	24"	26"	28"	30"	34"	36"	40"	42"
Weight (Lbs.) Per Foot 4" Roller Centers	51	53	55	57	59	61	63	67	69	73	75
Weight (Lbs.) Per Foot 6" Roller Centers	46	48	50	52	54	56	58	62	64	66	68

Total Weight = (Number of Zones x 30) + (OAL x Weight Per Foot)  
 All weights in catalog are conveyor weights only. Accessories, crating, etc. are not included.



U.S. Patent Numbers  
 5,862,907 • 7,243,781 • 7,591,366 • 6,860,381  
 Other Patents Pending.



## HOW IT WORKS

The conveyor is made up of accumulation zones. Each zone contains an individual zone drive interfaced to Hytrol's EZLogic® Zone Controllers, which sense product presence and control the accumulation and release of the zones by starting and stopping the zone drives.

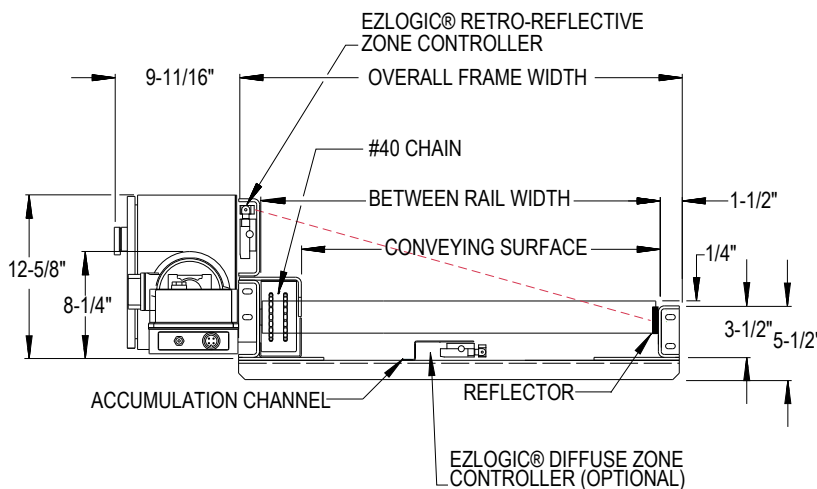
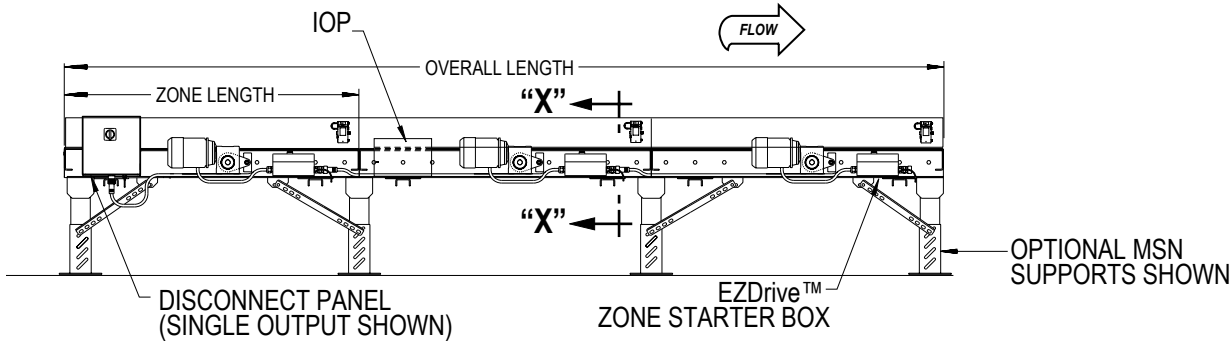

VIEW X-X  
DISCONNECT PANEL



## • STANDARD SPECIFICATIONS

**BED**—Roller bed with 1.9 in. dia. x 9 ga. unplated rollers spaced every 4 or 6 in. Tread rollers mounted in 3 1/2 in. x 7 ga. formed channel on side opposite chain guard and 4 3/4 in. x 7 ga. formed channel on chain guard side. Bolted together with butt couplings.

**DRIVE CHAIN**—No. 40 roller-to-roller.

**CHAIN GUARD**—Formed steel guards totally enclose drive chains.

**EZDrive™ System**—Shaft mounted gearmotor located near center of each zone. 1/2 HP - 3 PH 60 Hz. Totally enclosed fan cooled. 230/460 V (specify voltage). Includes EZDrive™ Disconnect Panel. Power is distributed zone to zone through pluggable cordsets. Power is connected from the starter box to the motor via "SO" type cord. Please contact factory if local code requires other than the standard power distribution techniques described.

**ACCUMULATION ZONES**—4 in. roller centers, 32 in. to 120 in. on 4 in. increments. 6 in. centers, 30 in. to 120 in. on 6 in. increments. Frame length changes with zone length.

**EZLOGIC™ ZONE CONTROLLER**—Located in each zone (Retro-Reflective). NEMA 1, 2, IP 62. UL Approved.

**IOP**—Provides 27VDC, 100 watt power for EZLogic™ accumulation system - contains slots for 4 input/output boards. Should be located near disconnect panel. See chart for maximum quantity of zones. Requires 120VAC or 230VAC single phase input.

**CONVEYING SPEED**—Constant 35 FPM.

**CAPACITY**—Maximum load per linear foot of conveyor 150 lbs. with supports on 10 ft. centers, 250 lbs. per ft. with supports on 5 ft. centers. Not to exceed 1000 lbs per zone. Zones longer than 6 ft. may require an additional floor support depending on product load.

**FLOOR SUPPORTS**—Now supplied as optional equipment.

DISCONNECT PANEL	230V	460V
		3 Ph. 60 Hz
SINGLE OUTPUT	1-8 ZONES	1-15 ZONES
DUAL OUTPUT	9-16 ZONES	16-22 ZONES

† **Note:** Infeed Wake-Up Eye used only on terminating infeed end of conveyor. Not used when connecting to upstream EZLogic™ conveyor through power supply isolation cable.

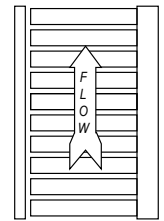

**RH CHAIN GUARD (STANDARD)**

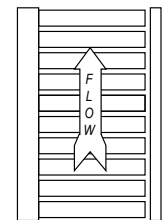

**LH CHAIN GUARD**

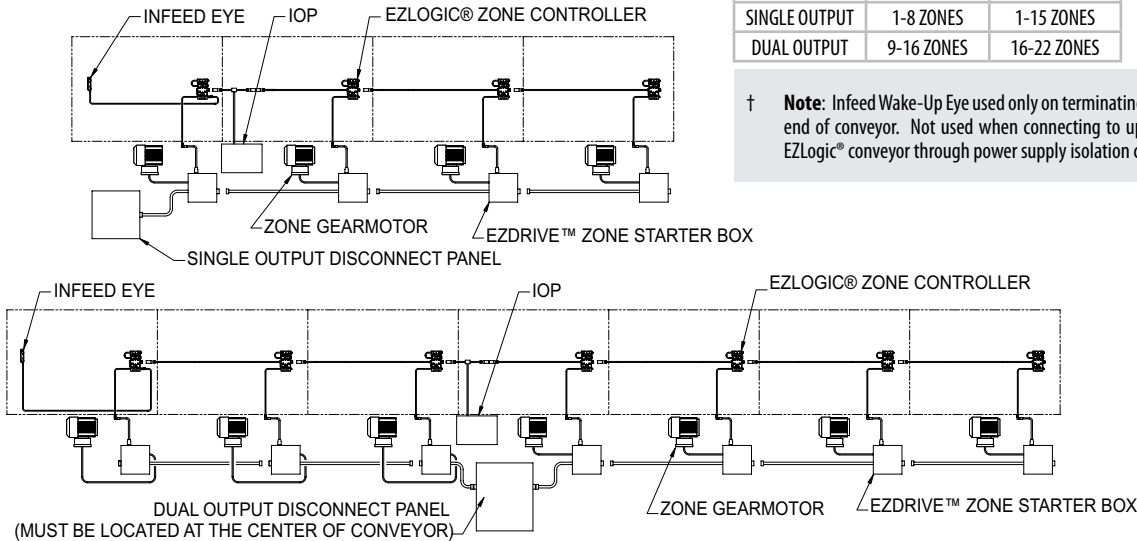

### EZLOGIC™ ACCUMULATION SYSTEM

Hytrol's EZLogic™, or "Electronic Zero-pressure Logic" Accumulation System, combines the sensing accuracy of photo-electronics with discrete electronic logic control without the use of a PLC or pneumatic logic components. The EZLogic™ Accumulation System provides many features including:

Zero-Pressure Accumulation of Product

**Zone Stop** - Function is built in. Any zone may be transformed into a workstation by connecting a dry contact switching device to the auxiliary port of the EZLogic™ Zone Controller. This feature is always used at the discharge end of the conveyor line, and may be used at any other location where a zone stop is required.

**Dynamic Zone Allocation** - Automatically adjusts the conveyor's zone length to accommodate the length of the product being conveyed. Improves conveyor efficiency and system flexibility.

**Sleep Feature** - Stops tread rollers from turning when no product is present, reducing noise, reducing energy consumption and extending roller bearing life.

**Unloading Zone Feature - Zone On Delay** - Timer delays the zone immediately upstream from a removed load, preventing it from driving for a set time. This feature is ideal where loads are routinely removed from the conveyor with a lift truck.

**Loading Zone Feature** - Zone detects load being placed onto the conveyor with a fork truck and stops the zone from driving and automatically prevents any loads in zones upstream from entering loading area.

## • OPTIONAL EQUIPMENT

**FLOOR SUPPORTS**—MSN Type floor supports are available with a wide range of adjustment. Specify top of belt or roller elevation. One support required at every bed joint and ends of conveyor. Holes in feet for lagging to floor. Knee braces recommended above MSN-6 support.

**CONVEYING SPEED**—Other constant and variable speeds. **Note:** Capacity affected with speed change.

**UNDERSIDE MOUNTED DRIVE**—Minimum elevation top of rollers-17 in.

**ROLLERS SET LOW**—Tread rollers mounted in 4 3/4 in. x 7 ga. formed steel channel frame to form 1 1/4 in. high guard rails.

**GUARD RAILS**—Adjustable Universal Channel Guard Rail, (both sides) fixed channel (both sides) or angle (one side).

**POLY-TIER SUPPORTS**—36 in. to 120 in. support heights in 6 in. increments. Knee braces supplied.

**CEILING HANGERS**—5/8 in. dia. x 8 ft. long unplated rods fully threaded. Other lengths and galvanized rods available.

### EZDrive™ System:

- Variable Frequency Drive—for adjusting conveying speed or adjusting acceleration and deceleration time.

**EZLogic™** - See EZLogic™ Components Page.